

Rondelle sferiche / Rosette coniche come DIN 6319, acciaio inox EH 23050.

Descrizione prodotto

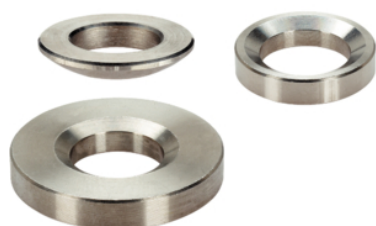

Campi di applicazione

Spherical washers / Conical seats are used as washers in a screw connection to compensate non-parallel surfaces.

Materiale

Rosetta conica
 • Acciaio inox 1.4305
 • Acciaio inox A4

Rondella sferica
 • Acciaio inox 1.4305
 • Acciaio inox A4

Assemblaggio

Le rosette esec. D servono per appoggi piani e rotondi.
 Per fori asolati è necessario usare le rosette esec. G.

Maggiori informazioni

Altri prodotti

- Rondelle sferiche / Rosette coniche, DIN 6319
- Dadi esagonali, DIN 6330 (altezza 1,5 d)

Disegno

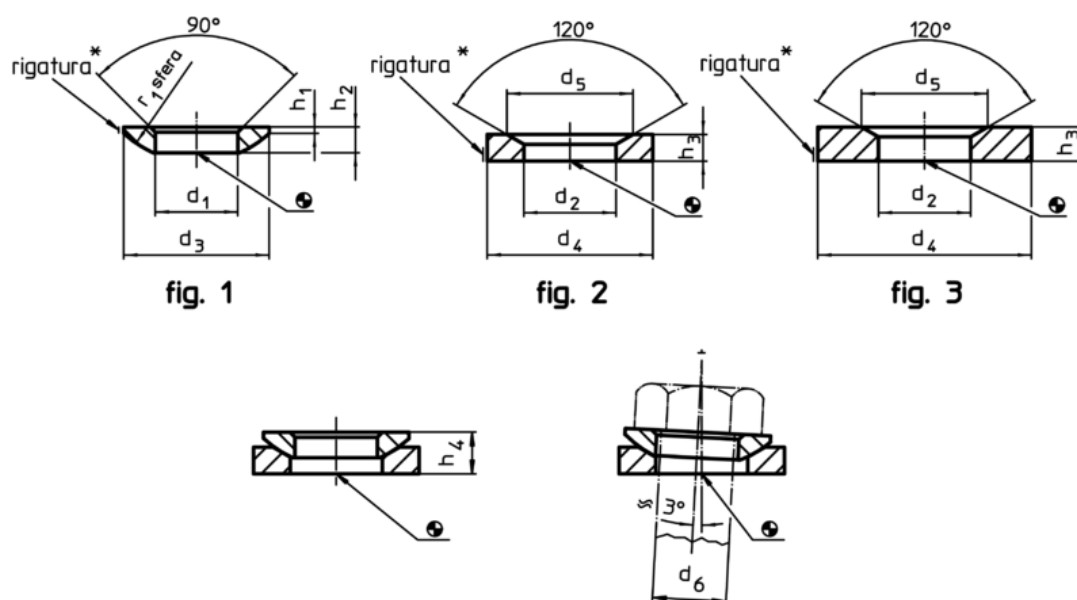

* Rigatura = acciaio inox A4

Caratteristiche

Dimensioni											Per viti d_6	Carico solo statico max.	Coppia per collegamenti a vite ¹⁾ max.		Cod.	
d_1 H13	d_2 H13	d_3	d_4	d_5	h_1	h_2	h_3	h_4 con rosetta conica forma D ~	h_4 con rosetta conica forma G ~	r_1						
[mm]											[mm]	[kN]	[Nm]	[g]		
Rondelle sferiche in acciaio inox forma C – Fig. 1, Acciaio inox 1.4305																
6,4	-	12	-	-	0,7	2,3	-	4,0	5,2	9	6	M 6	6	6	1,1	23050.0306
8,4	-	17	-	-	0,6	3,2	-	5,3	6,8	12	8	M 8	12	16	2,8	23050.0308
10,5	-	21	-	-	0,8	4,0	-	6,3	7,1	15	10	M10	16	32	5,2	23050.0310
13,0	-	24	-	-	1,1	4,6	-	7,9	8,9	17	12	M12	24	56	7,7	23050.0312
17,0	-	30	-	-	1,3	5,3	-	9,3	10,1	22	16	M16	45	135	13,0	23050.0316
21,0	-	36	-	-	2,0	6,3	-	11,6	12,1	27	20	M20	71	280	23,0	23050.0320
25,0	-	44	-	-	2,4	8,2	-	14,9	15,4	32	24	M24	105	455	46,0	23050.0324

¹⁾ Il valore della coppia delle viti A2-70 è indicativo, considerare eventuali prearichi. Valori indicati con un coefficiente d'attrito μ_{totale} 0,12.

Dimensioni											Per viti		Carico solo statico max.	Coppia per collegamenti a vite ¹⁾ max.		Cod.
d ₁ H13	d ₂ H13	d ₃	d ₄	d ₅	h ₁	h ₂	h ₃	h ₄ con rosetta conica forma D ~	h ₄ con rosetta conica forma G ~	r ₁	d ₆					
[mm]											[mm]		[kN]	[Nm]	[g]	
31,0	-	56	-	-	3,6	11,2	-	18,8	18,8	41	30	M30	191	1050	104,0	23050.0330
37,0	-	68	-	-	4,6	14,0	-	23,4	-	50	36	M36	-	-	193,0	23050.0336
43,0	-	78	-	-	6,5	17,0	-	28,3	-	58	42	M42	-	-	313,0	23050.0342
50,0	-	92	-	-	8,0	21,0	-	35,0	-	67	48	M48	-	-	545,0	23050.0348
Rondelle sferiche in acciaio inox forma C – Fig. 1, Acciaio inox A4																
6,4	-	12	-	-	0,7	2,3	-	4,0	5,2	9	6	M 6	6	6	1,1	23050.0606
8,4	-	17	-	-	0,6	3,2	-	5,3	6,8	12	8	M 8	12	16	2,8	23050.0608
10,5	-	21	-	-	0,8	4,0	-	6,3	7,1	15	10	M10	16	32	5,2	23050.0610
13,0	-	24	-	-	1,1	4,6	-	7,9	8,9	17	12	M12	24	56	7,7	23050.0612
17,0	-	30	-	-	1,3	5,3	-	9,3	10,1	22	16	M16	45	135	13,0	23050.0616
21,0	-	36	-	-	2,0	6,3	-	11,6	12,1	27	20	M20	71	280	23,0	23050.0620
25,0	-	44	-	-	2,4	8,2	-	14,9	15,4	32	24	M24	105	455	46,0	23050.0624
31,0	-	56	-	-	3,6	11,2	-	18,8	18,8	41	30	M30	191	1050	104,0	23050.0630
37,0	-	68	-	-	4,6	14,0	-	23,4	-	50	36	M36	-	-	193,0	23050.0636
43,0	-	78	-	-	6,5	17,0	-	28,3	-	58	42	M42	-	-	313,0	23050.0642
50,0	-	92	-	-	8,0	21,0	-	35,0	-	67	48	M48	-	-	545,0	23050.0648
Rosette coniche in acciaio inox forma D – Fig. 2, Acciaio inox 1.4305																
-	7,1	-	12	11,0	-	-	2,8	-	-	-	6	M 6	6	6	1,4	23050.0406
-	9,6	-	17	14,5	-	-	3,5	-	-	-	8	M 8	12	16	3,8	23050.0408
-	12,0	-	21	18,5	-	-	4,2	-	-	-	10	M10	16	32	6,5	23050.0410
-	14,2	-	24	20,0	-	-	5,0	-	-	-	12	M12	24	56	11,0	23050.0412
-	19,0	-	30	26,0	-	-	6,2	-	-	-	16	M16	45	135	19,0	23050.0416
-	23,2	-	36	31,0	-	-	7,5	-	-	-	20	M20	71	280	32,0	23050.0420
-	28,0	-	44	37,0	-	-	9,5	-	-	-	24	M24	105	455	63,0	23050.0424
-	35,0	-	56	49,0	-	-	12,0	-	-	-	30	M30	191	1050	127,0	23050.0430
-	42,0	-	68	60,0	-	-	15,0	-	-	-	36	M36	-	-	234,0	23050.0436
-	49,0	-	78	70,0	-	-	18,0	-	-	-	42	M42	-	-	362,0	23050.0442
-	56,0	-	92	82,0	-	-	22,0	-	-	-	48	M48	-	-	642,0	23050.0448
Rosette coniche in acciaio inox forma D – Fig. 2, Acciaio inox A4																
-	7,1	-	12	11,0	-	-	2,8	-	-	-	6	M 6	6	6	1,4	23050.0666
-	9,6	-	17	14,5	-	-	3,5	-	-	-	8	M 8	12	16	3,8	23050.0668
-	12,0	-	21	18,5	-	-	4,2	-	-	-	10	M10	16	32	6,5	23050.0670
-	14,2	-	24	20,0	-	-	5,0	-	-	-	12	M12	24	56	11,0	23050.0672
-	19,0	-	30	26,0	-	-	6,2	-	-	-	16	M16	45	135	19,0	23050.0676
-	23,2	-	36	31,0	-	-	7,5	-	-	-	20	M20	71	280	32,0	23050.0680
-	28,0	-	44	37,0	-	-	9,5	-	-	-	24	M24	105	455	63,0	23050.0684
-	35,0	-	56	49,0	-	-	12,0	-	-	-	30	M30	191	1050	127,0	23050.0686
-	42,0	-	68	60,0	-	-	15,0	-	-	-	36	M36	-	-	234,0	23050.0688
-	49,0	-	78	70,0	-	-	18,0	-	-	-	42	M42	-	-	362,0	23050.0692
-	56,0	-	92	82,0	-	-	22,0	-	-	-	48	M48	-	-	642,0	23050.0694
Rosette coniche in acciaio inox forma G – Fig. 3, Acciaio inox 1.4305																
-	7,1	-	17	11,0	-	-	4,0	-	-	-	6	M 6	6	6	5,8	23050.0466
-	9,6	-	24	14,5	-	-	5,0	-	-	-	8	M 8	12	16	15,0	23050.0468
-	12,0	-	30	18,5	-	-	5,0	-	-	-	10	M10	16	32	22,0	23050.0470
-	14,2	-	36	20,0	-	-	6,0	-	-	-	12	M12	24	56	40,0	23050.0472
-	19,0	-	44	26,0	-	-	7,0	-	-	-	16	M16	45	135	66,0	23050.0476
-	23,2	-	50	31,0	-	-	8,0	-	-	-	20	M20	71	280	95,0	23050.0480
-	28,0	-	60	37,0	-	-	10,0	-	-	-	24	M24	105	455	171,0	23050.0484
-	35,0	-	68	49,0	-	-	12,0	-	-	-	30	M30	191	1050	236,0	23050.0490
Rosette coniche in acciaio inox forma G – Fig. 3, Acciaio inox A4																
-	7,1	-	17	11,0	-	-	4,0	-	-	-	6	M 6	6	6	5,8	23050.0706
-	9,6	-	24	14,5	-	-	5,0	-	-	-	8	M 8	12	16	15,0	23050.0708
-	12,0	-	30	18,5	-	-	5,0	-	-	-	10	M10	16	32	22,0	23050.0710
-	14,2	-	36	20,0	-	-	6,0	-	-	-	12	M12	24	56	40,0	23050.0712

¹⁾ Il valore della coppia delle viti A2-70 è indicativo, considerare eventuali precarichi. Valori indicati con un coefficiente d'attrito μ_{totale} 0,12.

Dimensioni											Per viti d_6	Carico solo statico max.	Coppia per collegamenti a vite ¹⁾ max.		Cod.	
d_1 H13	d_2 H13	d_3	d_4	d_5	h_1	h_2	h_3	h_4 con rosetta conica forma D ~	h_4 con rosetta conica forma G ~	r_1						
[mm]											[mm]	[kN]	[Nm]	[g]		
-	19,0	-	44	26,0	-	-	7,0	-	-	-	16	M16	45	135	66,0	23050.0716
-	23,2	-	50	31,0	-	-	8,0	-	-	-	20	M20	71	280	95,0	23050.0720
-	28,0	-	60	37,0	-	-	10,0	-	-	-	24	M24	105	455	171,0	23050.0724
-	35,0	-	68	49,0	-	-	12,0	-	-	-	30	M30	191	1050	236,0	23050.0730

¹⁾ Il valore della coppia delle viti A2-70 è indicativo, considerare eventuali precarichi. Valori indicati con un coefficiente d'attrito μ_{totale} 0,12.

Esempio di applicazione

