

## Spie olio EH 22860.

### Descrizione prodotto

Le spie olio possono essere utilizzate per il controllo di livello in serbatoi senza sovrappressione.



#### Materiale

##### Guarnizione

- Resistente a olii e benzina

##### Schermo

- Plastica, bianca

##### Ghiera

- Alluminio Al

##### Lente

- Plexiglas (PMMA) cristallino

#### Assemblaggio

Montate in fori lisci tolleranza H11. Il serraggio avviene ruotando la ghiera.

### Disegno

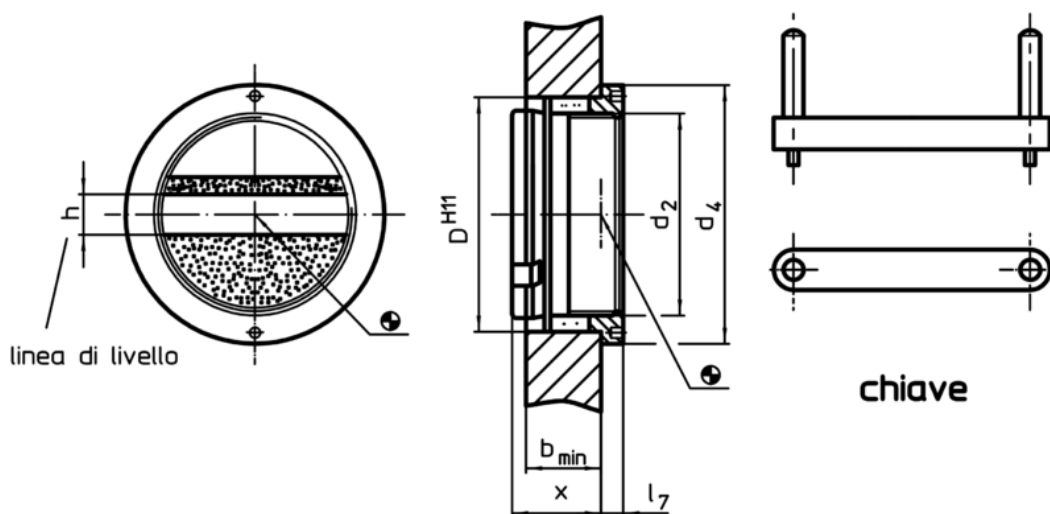

### Caratteristiche

Grand. (Ø lente) d <sub>1</sub>	Dimensioni							Foro di ricezione D H11 [mm]	Temperatura		Peso [g]	Cod.
	d <sub>2</sub>	d <sub>3</sub>	x ~ [mm]	l <sub>1</sub>	b min.	h	e		min.	max.		
<b>Senza linee di livello</b>												
16	25	2,2	15	3,5	9	–	21,0	20	-20	70	9,0	22860.0016
22	35	3,0	15	4,5	10	–	30,0	28	-20	70	18,0	22860.0022
32	45	3,0	18	5,5	12	–	40,0	38	-20	70	33,0	22860.0032
50	64	3,0	22	5,5	14	–	58,5	58	-20	70	87,0	22860.0050
<b>Con linee di livello</b>												
16	25	2,2	15	3,5	9	5	21,0	20	-20	70	8,9	22860.0116
22	35	3,0	15	4,5	10	6	30,0	28	-20	70	18,0	22860.0122
32	45	3,0	18	5,5	12	8	40,0	38	-20	70	33,0	22860.0132
50	64	3,0	22	5,5	14	10	58,5	58	-20	70	86,0	22860.0150

Accessori

	Grand. (Ø lente) d <sub>1</sub>	Dimensioni		e	[g]	Cod.
		d h9 [mm]				
<b>Attrezzo di montaggio</b>						
	16	2,0		21,0	16	<a href="#">22860.0816</a>
	22	2,8		30,0	30	<a href="#">22860.0822</a>
	32	2,8		40,0	36	<a href="#">22860.0832</a>
	50	2,8		58,5	49	<a href="#">22860.0850</a>

Esempio di applicazione

